

017

Sonden, Aspiration  
Probes, Aspiration  
Sondas, Aspiración  
Sonde, Aspirazione



017

Sonden  
Probes  
Sondas  
Sonde



ø 1,0 mm	ø 1,5 mm	ø 2,0 mm	
<b>017-010-115</b>	<b>017-012-115</b>	<b>017-014-115</b>	11,5 cm / 4 <sup>1</sup> / <sub>2</sub> "
<b>017-010-130</b>	<b>017-012-130</b>	<b>017-014-130</b>	13,0 cm / 5"
<b>017-010-145</b>	<b>017-012-145</b>	<b>017-014-145</b>	14,5 cm / 5 <sup>3</sup> / <sub>4</sub> "
<b>017-010-160</b>	<b>017-012-160</b>	<b>017-014-160</b>	16,0 cm / 6 <sup>1</sup> / <sub>4</sub> "
<b>017-010-180</b>	<b>017-012-180</b>	<b>017-014-180</b>	18,0 cm / 7"
<b>017-010-200</b>	<b>017-012-200</b>	<b>017-014-200</b>	20,0 cm / 8"
	<b>017-012-250</b>	<b>017-014-250</b>	25,0 cm / 9 <sup>3</sup> / <sub>4</sub> "
		<b>017-014-300</b>	30,0 cm / 11 <sup>3</sup> / <sub>4</sub> "

ø 2,0 mm	
<b>017-020-115</b>	11,5 cm / 4 <sup>1</sup> / <sub>2</sub> "
<b>017-020-130</b>	13,0 cm / 5"
<b>017-020-145</b>	14,5 cm / 5 <sup>3</sup> / <sub>4</sub> "
<b>017-020-160</b>	16,0 cm / 6 <sup>1</sup> / <sub>4</sub> "
<b>017-020-180</b>	18,0 cm / 7"
<b>017-020-200</b>	20,0 cm / 8"
<b>017-020-250</b>	25,0 cm / 9 <sup>3</sup> / <sub>4</sub> "

ø 1,0 mm



Silber  
Silver  
Plata  
argento



**STACKE**

ø 1,5 mm	
<b>017-030-105</b>	10,5 cm / 4 <sup>1</sup> / <sub>8</sub> "

ø 1,5 mm	ø 2,0 mm	
-	<b>017-040-130</b>	13,0 cm / 5"
<b>017-035-145</b>	<b>017-040-145</b>	14,5 cm / 5 <sup>3</sup> / <sub>4</sub> "
-	<b>017-040-160</b>	16,0 cm / 6 <sup>1</sup> / <sub>4</sub> "
-	<b>017-040-180</b>	18,0 cm / 7"
-	<b>017-040-200</b>	20,0 cm / 8"

ø 3,5 mm	
<b>017-050-115</b>	11,5 cm / 4 <sup>1</sup> / <sub>2</sub> "
<b>017-050-130</b>	13,0 cm / 5"
<b>017-050-145</b>	14,5 cm / 5 <sup>3</sup> / <sub>4</sub> "
<b>017-050-160</b>	16,0 cm / 6 <sup>1</sup> / <sub>4</sub> "
<b>017-050-180</b>	18,0 cm / 7"
<b>017-050-200</b>	20,0 cm / 8"



ø 3,3 mm

- 017-060-130** 13,0 cm / 5"
- 017-060-145** 14,5 cm / 5<sup>3</sup>/<sub>4</sub>"
- 017-060-160** 16,0 cm / 6<sup>1</sup>/<sub>4</sub>"
- 017-060-180** 18,0 cm / 7"
- 017-060-200** 20,0 cm / 8"



**DOYEN**

- 017-071-145** 14,5 cm / 5<sup>3</sup>/<sub>4</sub>"



**NELATON**

- 017-073-160** 16,0 cm / 6<sup>1</sup>/<sub>4</sub>"



**BRODIE**

- 017-080-200** 20,0 cm / 8"



**LOCKHARD-MUMMERY**

- 017-090-001** 16,5 cm / 6<sup>1</sup>/<sub>2</sub>"

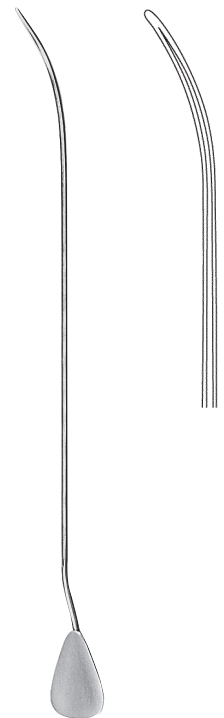

**LOCKHARD-MUMMERY**

- 017-090-002** 16,5 cm / 6<sup>1</sup>/<sub>2</sub>"



017

Sonden, Phlebotomier  
Probes, Phlebotomizers  
Sondas, Flebotomizadores  
Sonda, Flebo-dissettori

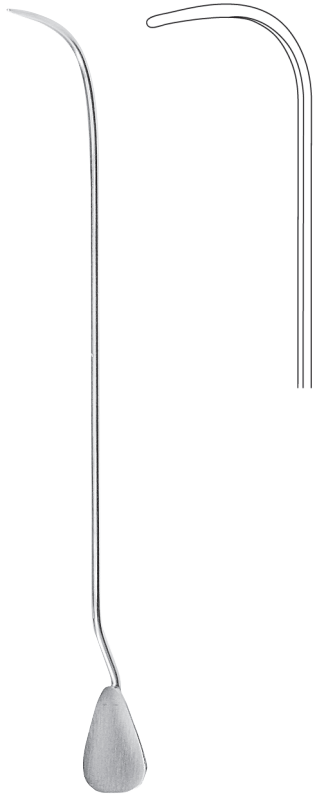

**LOCKHARD-MUMMERY**

**017-090-003** 16,5 cm / 6 1/2"

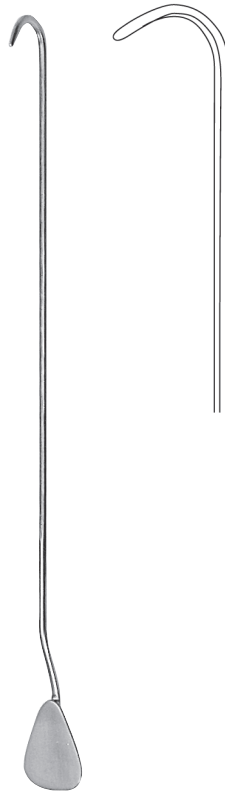

**LOCKHARD-MUMMERY**

**017-090-004** 16,5 cm / 6 1/2"

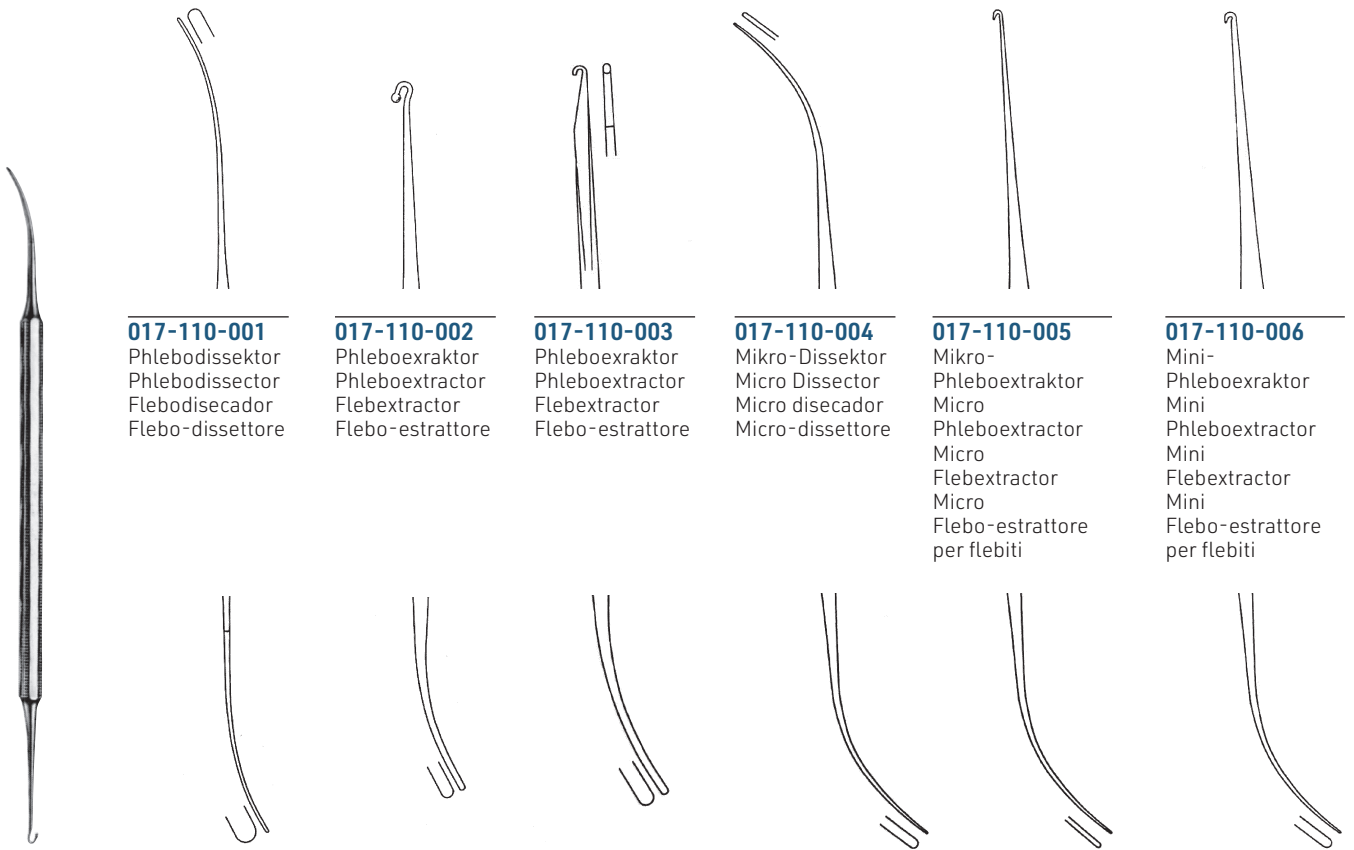

**017-110-001**

Phlebotomier  
Phlebotomizer  
Flebotomizador  
Flebo-dissettori

**017-110-002**

Phleboextraktor  
Phleboextractor  
Flebextractor  
Flebo-estrattore

**017-110-003**

Phleboextraktor  
Phleboextractor  
Flebextractor  
Flebo-estrattore

**017-110-004**

Mikro-Dissektor  
Micro Dissector  
Micro disecador  
Micro-dissettori

**017-110-005**

Mikro-  
Phleboextraktor  
Micro  
Phleboextractor  
Micro  
Flebextractor  
Micro  
Flebo-estrattore  
per flebiti

**017-110-006**

Mini-  
Phleboextraktor  
Mini  
Phleboextractor  
Mini  
Flebextractor  
Mini  
Flebo-estrattore  
per flebiti

**VARADY**

**017-110-001 - 017-110-006**

18,0 cm / 7"



**017-100-001** 135x100x25 mm

Metalletui  
 Metal case  
 Estuche de metal  
 Scatola in metallo

**NABATOFF**

**017-100-000**

komplett  
 complete  
 completo  
 completo



**017-100-003**  
 Ø 3,0 mm



**017-100-006**  
 Ø 6,0 mm



**017-100-009**  
 Ø 9,0 mm

**017-100-021**

Zugseil  
 Cable  
 Cable  
 Fune

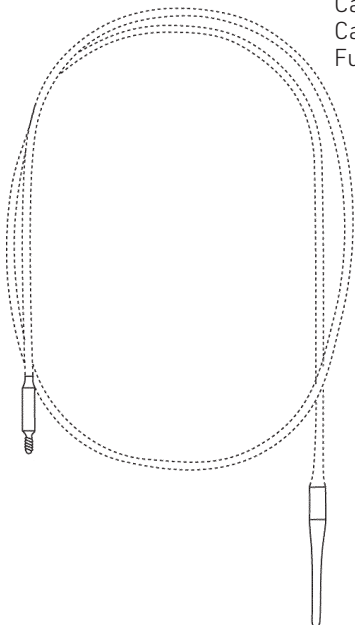

**017-100-012**  
 Ø 12,0 mm



**017-100-015**  
 Ø 15,0 mm

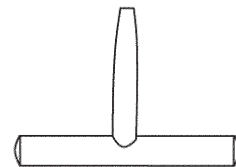

**017-100-020**  
 Handgriff  
 Handle  
 Mango  
 Manico

**017-100-002**

Kunststoff-Sondenspitze  
 Plastic probe tip  
 Punta de sonda de plastico  
 Punta di sonda di plastica



017

Sonden, Phlebotisektor  
Probes, Phlebotisectors  
Sondas, Flebotisecadores  
Sonde, Flebo-dissettori



**VOLLMAR**

**017-120-002 - 017-120-012** 50 cm / 19<sup>3</sup>/<sub>4</sub>"

**017-122-120** 12,0 cm / 4<sup>3</sup>/<sub>3</sub>"

Handgriff für Ringstripper nach Vollmar  
Handle for Vollmar Ring Stripper  
Mango para Vollmar fleboextractor  
Manico per stripper anello di Vollmar



**JOBSON-HORNE**

**017-150-180** 18,0 cm / 7"



**UCKERMANN**

**017-154-160** 16,0 cm / 6 1/4"



**FARRELL**

<b>017-160-120</b>	Ø 0,9 mm	12,0 cm / 4 3/4"
<b>017-160-140</b>	Ø 0,9 mm	14,0 cm / 5 1/2"
<b>017-160-160</b>	Ø 1,1 mm	16,5 cm / 6 1/2"
<b>017-160-180</b>	Ø 1,2 mm	18,0 cm / 7"



**FARRELL**

<b>017-170-120</b>	Ø 0,9 mm	12,0 cm / 4 3/4"
<b>017-170-140</b>	Ø 0,9 mm	14,0 cm / 5 1/2"
<b>017-170-160</b>	Ø 1,1 mm	16,5 cm / 6 1/2"
<b>017-170-180</b>	Ø 1,2 mm	18,0 cm / 7"

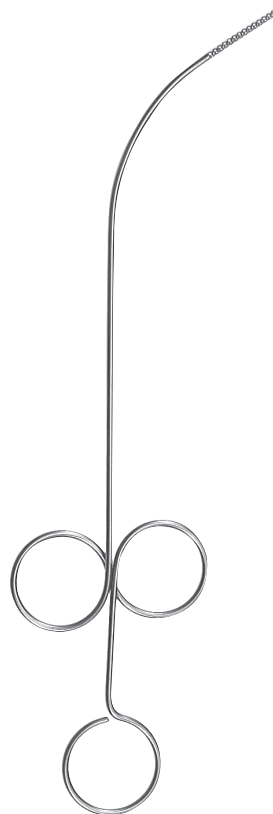

**FEIN**

**017-180-280** 28,0 cm / 11"

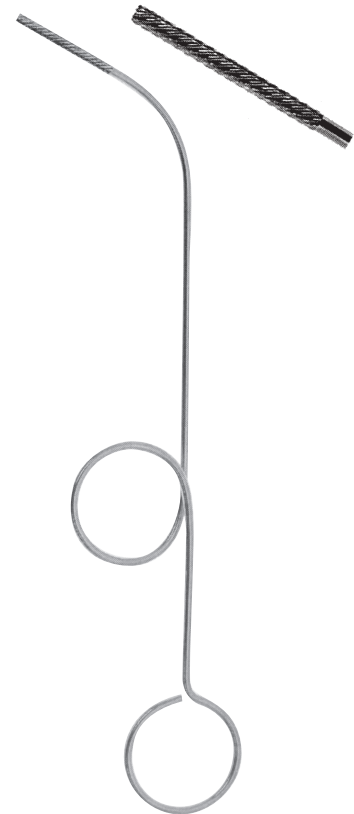

**PELTESON**

**017-184-230** 23,0 cm / 9"



017

Trokare  
Trocars  
Trócares  
Trequarti

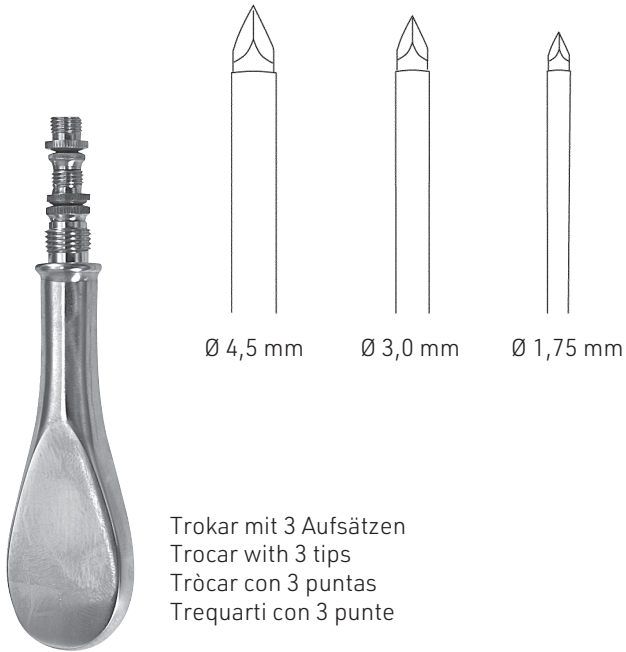

Trokar mit 3 Aufsätzen  
Trocar with 3 tips  
Tròcar con 3 puntas  
Trequarti con 3 punte

**UNIVERSAL**  
017-200-003

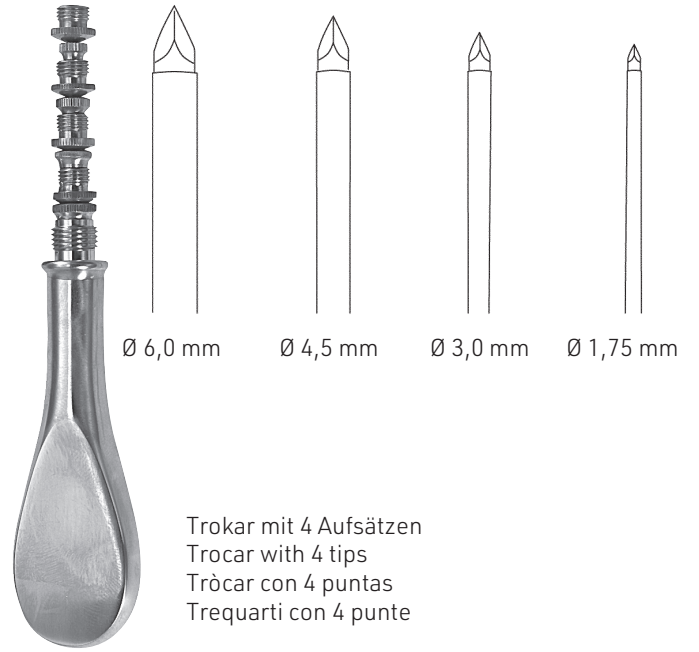

Trokar mit 4 Aufsätzen  
Trocar with 4 tips  
Tròcar con 4 puntas  
Trequarti con 4 punte

**UNIVERSAL**  
017-200-004



**STANDARD**

- 017-210-030    Ø 3,0 mm
- 017-210-035    Ø 3,5 mm
- 017-210-040    Ø 4,0 mm
- 017-210-045    Ø 4,5 mm
- 017-210-050    Ø 5,0 mm
- 017-210-055    Ø 5,5 mm
- 017-210-060    Ø 6,0 mm

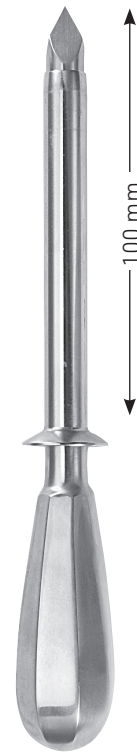

**NELSON**

- 017-220-075    Ø 7,5 mm
- 017-220-090    Ø 9,0 mm
- 017-220-110    Ø 11,0 mm





**OCHSNER**

017-230-040 Ø 4,0 mm  
017-230-055 Ø 5,5 mm  
017-230-065 Ø 6,5 mm



Kieferhöhlentrokare  
Antrum trocars  
Trócares para el seno maxilar  
Trequarti per puntura del seno  
mascellare

**LICHTWITZ**

017-240-190 19,0 cm / 7 1/2"



**DOUGLAS**

017-250-110 Ø 3,0 mm



**KRAUSE**

017-260-040 Ø 4,0 mm  
017-260-055 Ø 5,5 mm



**PIERCE**

017-265-040 Ø 4,0 mm



**BUELAU**

017-270-080 Ø 8,0 mm



017

Trokare, Saugrohre  
Trocars, Suction Tubes  
Trócares, Tubos para aspiración  
Trequarti, Tubi aspirazione



Ø 2,0 mm

**LANDAU**

**017-280-160** 16,0 cm / 6 1/4"



Ø 2,3 mm

**COAKLEY**

**017-290-140** 14,0 cm / 5 1/4"



Ø 4,0 mm

**ADSON**

**017-300-210** 21,0 cm / 8 1/4"

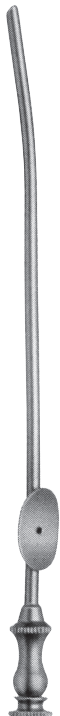

Ø 3,0 mm

**ADSON**

**017-301-165** 16,5 cm / 6 1/2"



**FRAZIER**

**017-310-010** Charr. 10 20,0 cm / 8"



**FRAZIER**

<b>017-311-006</b>	Charr. 6	19,0 cm / 7 1/2"
<b>017-311-007</b>	Charr. 7	19,0 cm / 7 1/2"
<b>017-311-008</b>	Charr. 8	19,0 cm / 7 1/2"
<b>017-311-009</b>	Charr. 9	19,0 cm / 7 1/2"
<b>017-311-010</b>	Charr. 10	19,0 cm / 7 1/2"
<b>017-311-011</b>	Charr. 11	19,0 cm / 7 1/2"
<b>017-311-012</b>	Charr. 12	19,0 cm / 7 1/2"



**POPPE**

<b>017-320-006</b>	Charr. 6	13,0 cm / 5"
<b>017-320-008</b>	Charr. 8	13,0 cm / 5"
<b>017-320-010</b>	Charr. 10	13,0 cm / 5"
<b>017-320-012</b>	Charr. 12	13,0 cm / 5"



**PLESTER**

<b>017-340-015</b>	Ø 1,5 mm	19,5 cm / 7 2/3"
<b>017-340-020</b>	Ø 2,0 mm	19,5 cm / 7 2/3"
<b>017-340-025</b>	Ø 2,5 mm	19,5 cm / 7 2/3"
<b>017-340-030</b>	Ø 3,0 mm	19,5 cm / 7 2/3"



**LEMPERT**

<b>017-350-020</b>	Ø 2,0 mm	20,0 cm / 8"
<b>017-350-030</b>	Ø 3,0 mm	20,0 cm / 8"



017

Sauginstrumente  
Aspirating Instruments  
Instrumentos de aspiración  
Strumenti per aspirazione



**COGSWELL**

**017-375-230** 23,0 cm / 9"



Präpariersauger  
Suction raspatory  
Aspirador para preparacion  
Aspiratore per preparazione

**LANDOLT**

**017-380-200** 20,0 cm / 8"



Nasensauger  
Nasal suction tube  
Tubo nasal para aspiración  
Tubo per aspirazione nasale

**KILNER**

**017-390-190** 19,0 cm / 7 1/2"



**MAGILL**

<b>017-400-030</b>	Ø 3,0 mm	24,5 cm / 6,9"
<b>017-400-035</b>	Ø 3,5 mm	24,5 cm / 6,9"
<b>017-400-040</b>	Ø 4,0 mm	24,5 cm / 6,9"

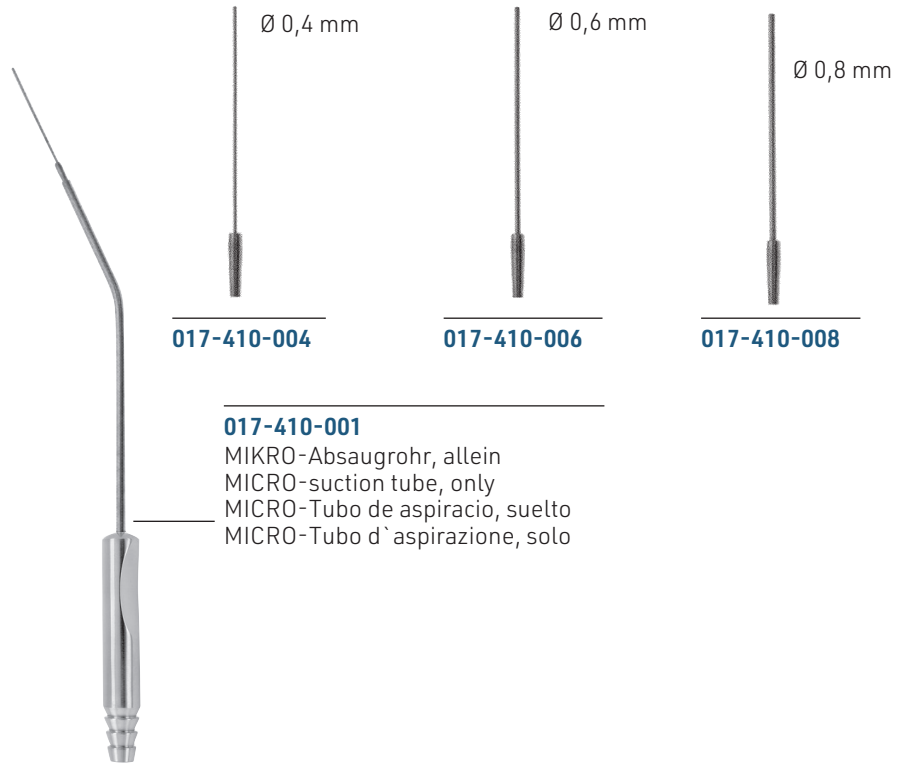

**WULLSTEIN**

**017-410-000** 17,0 cm / 6<sup>3</sup>/<sub>4</sub>"

- Komplett bestehend aus: 1 MIKRO-Absaugrohr mit LUER-Bohrung (017-410-001) und 3 MIKRO-Saugkanülen Ø 0,4 mm - Ø 0,8 mm (017-410-004, -006 und -008)
- Complete consisting of: 1 MICRO-Suction tube with LUER hub (017-410-001) and 3 MICRO-Suction cannulas Ø 0,4 mm - Ø 0,8 mm (017-410-004, -006 und -008)
- Completo compuesto de: 1 MICRO-Tubo de aspiración con cono LUER (017-410-001) y 3 MICRO-cánulas para aspiración Ø 0,4 mm - Ø 0,8 mm (017-410-004, -006 und -008)
- Completo composto da: 1 MICRO-Tubo d' aspirazione, perforazione LUER (017-410-001) e 3 MICRO-cannule d' aspirazione Ø 0,4 mm - Ø 0,8 mm (017-410-004, -006 und -008)

**017-420-001**

MIKRO-Absaugrohr, allein  
MICRO-suction tube, only  
MICRO-Tubo de aspiración, suelto  
MICRO-Tubo d' aspirazione, solo

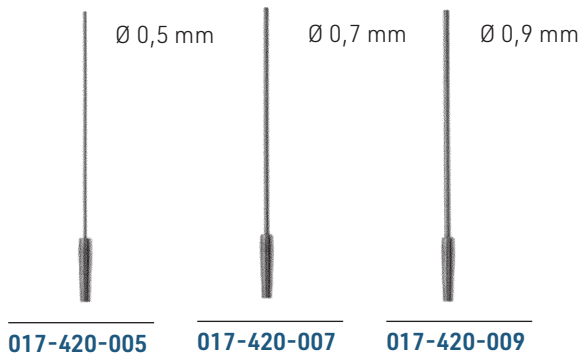
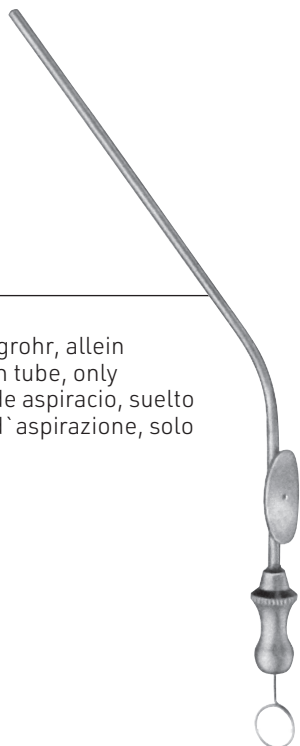

**BELLUCCI**

**017-420-000** 15,5 cm / 6"

- Komplett bestehend aus: 1 MIKRO-Absaugrohr mit LUER-Bohrung (017-420-001) und 3 MIKRO-Saugkanülen Ø 0,5 mm - Ø 0,9 mm (017-420-005, -007 und -009)
- Complete consisting of: 1 MICRO-Suction tube with LUER hub (017-420-001) and 3 MICRO-Suction cannulas Ø 0,5 mm - Ø 0,9 mm (017-420-005, -007 und -009)
- Completo compuesto de: 1 MICRO-Tubo de aspiración con cono LUER (017-420-001) y 3 MICRO-Cánulas para aspiración Ø 0,5 mm - Ø 0,9 mm (017-410-005, -007 und -009)
- Completo composto da: 1 MICRO-Tubo d' aspirazione, perforazione LUER (017-420-001) e 3 MICRO-Cannule d' aspirazione Ø 0,5 mm - Ø 0,9 mm (017-420-005, -007 und -009)



**SCHUKNECHT**

---

<b>017-430-005</b>	Ø 0,5 mm	13,0 cm / 5 1/8"
<b>017-430-009</b>	Ø 0,9 mm	13,0 cm / 5 1/8"



**BARRON**

---

<b>017-440-010</b>	Ø 1,0 mm	10,0 cm / 4"
<b>017-440-023</b>	Ø 2,3 mm	10,0 cm / 4"



**ZÖLLNER**

---

<b>017-451-005</b>	Ø 0,5 mm
<b>017-451-007</b>	Ø 0,7 mm
<b>017-451-009</b>	Ø 0,9 mm
<b>017-451-012</b>	Ø 1,2 mm

**ZÖLLNER**

---

<b>017-450-180</b>	18,0 cm / 7"
--------------------	--------------



**HOUSE**

---

<b>017-460-009</b>	Ø 0,9 mm/0,7 mm
<b>017-460-012</b>	Ø 1,2 mm/0,9 mm
<b>017-460-015</b>	Ø 1,5 mm/1,2 mm

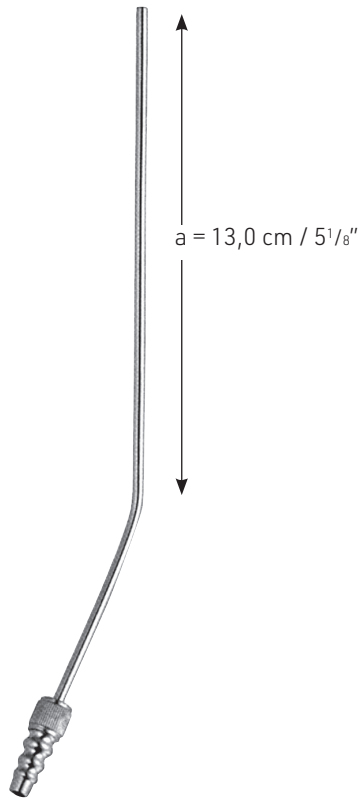

**YASARGIL**

- 017-470-015** Ø 1,5 mm
- 017-470-020** Ø 2,0 mm
- 017-470-025** Ø 2,5 mm
- 017-470-035** Ø 3,5 mm

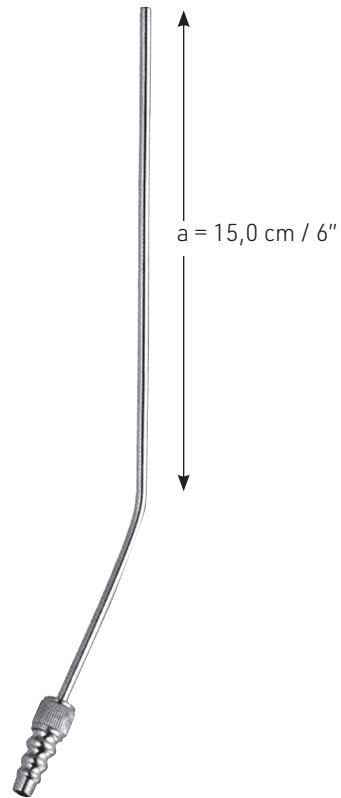

**YASARGIL**

- 017-472-015** Ø 1,5 mm
- 017-472-020** Ø 2,0 mm
- 017-472-025** Ø 2,5 mm
- 017-472-035** Ø 3,5 mm

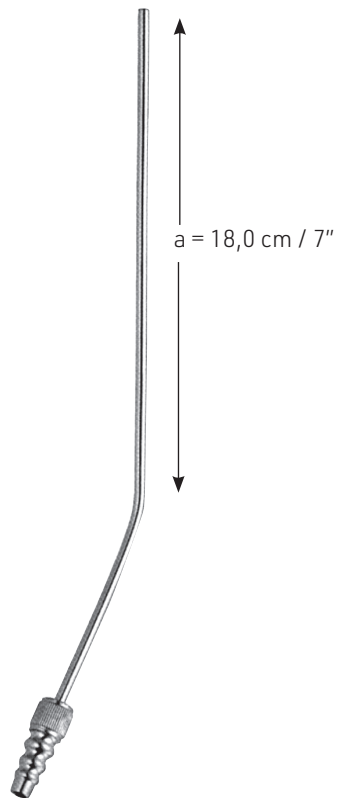

**YASARGIL**

- 017-474-015** Ø 1,5 mm
- 017-474-020** Ø 2,0 mm
- 017-474-025** Ø 2,5 mm
- 017-474-035** Ø 3,5 mm

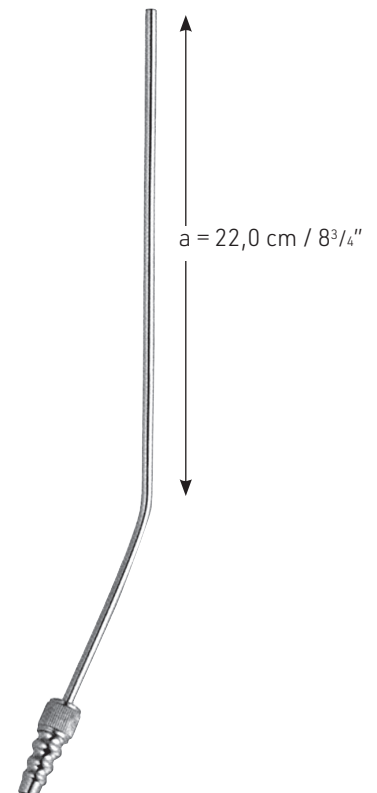

**YASARGIL**

- 017-476-015** Ø 1,5 mm
- 017-476-020** Ø 2,0 mm
- 017-476-025** Ø 2,5 mm
- 017-476-035** Ø 3,5 mm



017

Saug- und Spülinstrumente  
Aspirating and Irrigating Instruments  
Instrumentos de aspiración y de lavado  
Strumenti per aspirazione e lavaggio

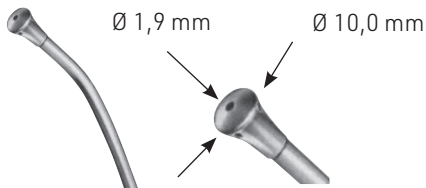

**017-480-271**  
Saugkopf allein  
Tip head only  
Cabeza de succión sola  
Testa di aspirazione solo

**YANKAUER**  
**017-480-270** 27,0 cm / 10<sup>3</sup>/<sub>4</sub>"

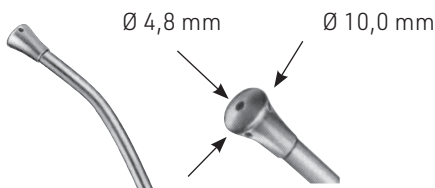

**YANKAUER**  
**017-490-285** 28,5 cm / 11<sup>1</sup>/<sub>4</sub>"



**ANDREWS-PYNCHON**  
**017-500-240** 24,0 cm / 9<sup>1</sup>/<sub>2</sub>"



**POOLE**  
**017-510-220** 22,0 cm / 8<sup>5</sup>/<sub>8</sub>"

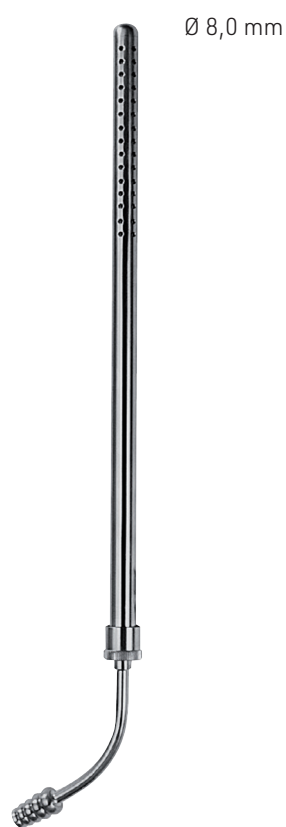

**POOLE**  
**017-511-220** 22,0 cm / 8<sup>5</sup>/<sub>8</sub>"



Ø 8,0 mm



**COOLEY**

**017-521-350** 35,0 cm / 13<sup>3</sup>/<sub>4</sub>"

Ø 7,0 mm



**COOLEY**

**017-523-300** 30,0 cm / 11<sup>3</sup>/<sub>4</sub>"

Ø 3,5 mm



**017-531-035**

Ø 3,5 mm

Ø 10,0 mm



**COOLEY**

**017-525-310** 31,0 cm / 11<sup>3</sup>/<sub>4</sub>"

Ø 8,0 mm



**COOLEY**

**017-527-330** 33,0 cm / 13"



**COUPLAND**

**017-530-170** 17,0 cm / 6<sup>3</sup>/<sub>4</sub>"



017

Spezialkanülen  
Special Needles  
Agujas especiales  
Aghi speciali

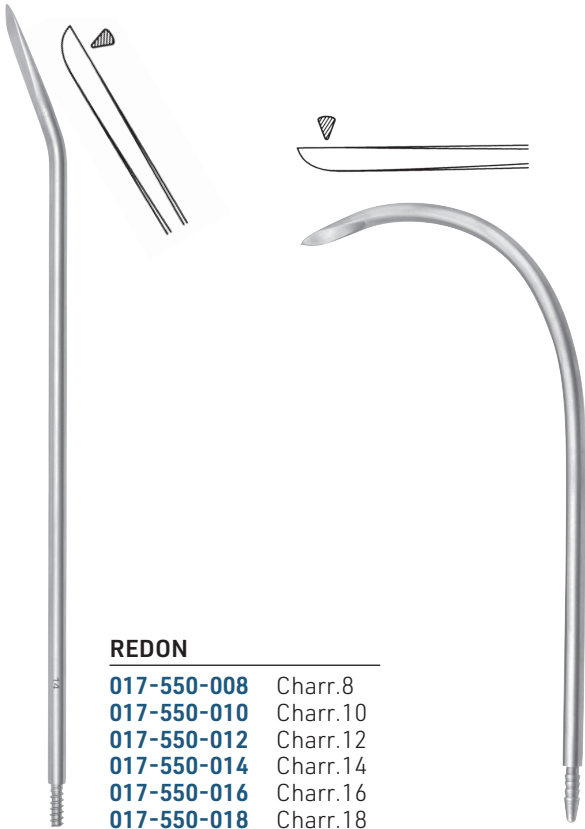

**REDON**

<b>017-550-008</b>	Charr.8
<b>017-550-010</b>	Charr.10
<b>017-550-012</b>	Charr.12
<b>017-550-014</b>	Charr.14
<b>017-550-016</b>	Charr.16
<b>017-550-018</b>	Charr.18

**REDON**

<b>017-560-008</b>	Charr.8
<b>017-560-010</b>	Charr.10
<b>017-560-012</b>	Charr.12
<b>017-560-014</b>	Charr.14
<b>017-560-016</b>	Charr.16
<b>017-560-018</b>	Charr.18



**REDON**

<b>017-570-008</b>	Charr.8
<b>017-570-010</b>	Charr.10
<b>017-570-012</b>	Charr.12
<b>017-570-014</b>	Charr.14
<b>017-570-016</b>	Charr.16
<b>017-570-018</b>	Charr.18



**REDON**

<b>017-580-008</b>	Charr.8
<b>017-580-010</b>	Charr.10
<b>017-580-012</b>	Charr.12
<b>017-580-014</b>	Charr.14
<b>017-580-016</b>	Charr.16
<b>017-580-018</b>	Charr.18

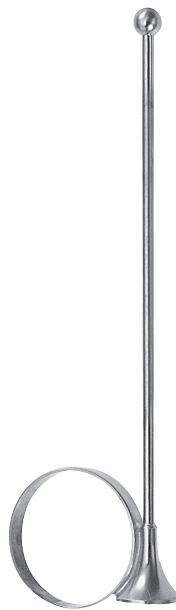

**IOWA**

<b>017-610-140</b>	14,0 cm / 5 1/4"
--------------------	------------------



**017-611-001**



---

**017-620-012** Ø 1,20x80 mm  
**017-620-015** Ø 1,50x80 mm



Kanülen zur Leberblindpunktion  
 Liver blind puncture needles  
 Aguja para punción ciega del hígado  
 Aghi per la punture cieca del fegato

**MENGHINI**

---

**017-630-001** Ø 1,00x 35 mm  
**017-630-002** Ø 1,00x 70 mm  
**017-630-003** Ø 1,20x 70 mm  
**017-630-004** Ø 1,20x 100 mm  
**017-630-005** Ø 1,40x 70 mm  
**017-630-006** Ø 1,40x 100 mm  
**017-630-007** Ø 1,60x 70 mm  
**017-630-008** Ø 1,60x 100 mm



**QUINKE**

---

**017-650-001** Ø 1,20x 76 mm  
**017-650-002** Ø 1,20x 89 mm  
**017-650-003** Ø 1,00x 76 mm  
**017-650-004** Ø 1,00x 89 mm  
**017-650-005** Ø 0,70x 76 mm  
**017-650-007** Ø 0,70x 89 mm



Kanülen zur Lumbalpunktion  
 Lumbar puncture needles  
 Aguja para punción lumbar  
 Aghi per punture lombari

**MENGHINI**

---

**017-640-014** Ø 1,40x168 mm  
**017-640-018** Ø 1,80x168 mm



017

Spezialkanülen  
Special Needles  
Agujas especiales  
Aghi speciali

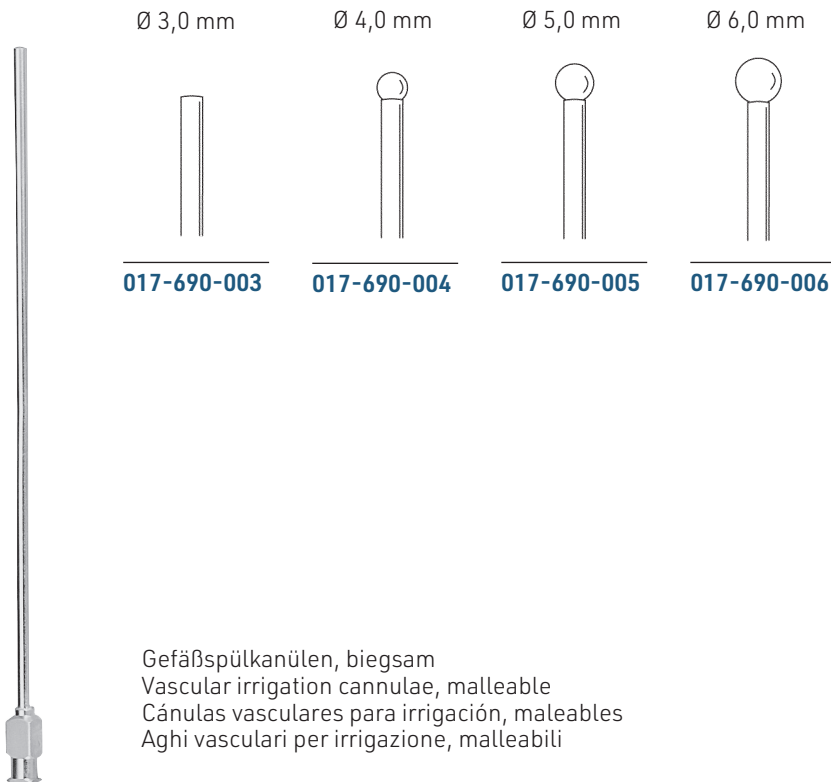

Gefäßspülkanülen, biegsam  
Vascular irrigation cannulae, malleable  
Cánulas vasculares para irrigación, maleables  
Aghi vascolari per irrigazione, malleabili

**SCHMID**

**017-690-003 - 017-690-006** 15,0 cm / 6"

Verbindungsstücke, Hähne  
Connecting Pieces, Stopcocks  
Piezas de conexión, Llaves  
Raccordi, Rubinetti



**017-760-006** Ø 6 mm  
**017-760-008** Ø 8 mm

Zwischenstück, LUER-LOCK männlich  
Connecting piece, LUER-LOCK male  
Pieza de conexión, LUER-LOCK masculino  
Raccordo, LUER-LOCK maschio



**LUER**

<b>017-800-001</b>	1 ml
<b>017-800-002</b>	2 ml
<b>017-800-005</b>	5 ml
<b>017-800-010</b>	10 ml
<b>017-800-020</b>	20 ml
<b>017-800-050</b>	50 ml



**LUER-LOCK**

<b>017-810-001</b>	1 ml
<b>017-810-002</b>	2 ml
<b>017-810-005</b>	5 ml
<b>017-810-010</b>	10 ml
<b>017-810-020</b>	20 ml
<b>017-810-050</b>	50 ml



**LUER-LOCK**

<b>017-820-002</b>	2 ml
<b>017-820-005</b>	5 ml
<b>017-820-010</b>	10 ml



<b>017-801-001</b>	1 ml
<b>017-801-002</b>	2 ml
<b>017-801-005</b>	5 ml
<b>017-801-010</b>	10 ml
<b>017-801-020</b>	20 ml
<b>017-801-050</b>	50 ml



<b>017-811-001</b>	1 ml
<b>017-811-002</b>	2 ml
<b>017-811-005</b>	5 ml
<b>017-811-010</b>	10 ml
<b>017-811-020</b>	20 ml
<b>017-811-050</b>	50 ml



<b>017-821-002</b>	2 ml
<b>017-821-005</b>	5 ml
<b>017-821-010</b>	10 ml



017

Spritzen, Ersatzzylinder  
Syringes, Spare barrel  
Jeringas, Cilindro de repuesto  
Siringhe, Cilindro di ricambio



**TUBERKULIN LUER LOCK**

**017-840-001** 1 ml



**JANET**

<b>017-850-050</b>	50 ml
<b>017-850-100</b>	100 ml
<b>017-850-150</b>	150 ml
<b>017-850-200</b>	200 ml



**LUER-LOCK**

<b>017-860-010</b>	10 ml
<b>017-860-020</b>	20 ml
<b>017-860-030</b>	30 ml
<b>017-860-050</b>	50 ml



**017-841-001** 1 ml



<b>017-851-050</b>	50 ml
<b>017-851-100</b>	100 ml
<b>017-851-150</b>	150 ml
<b>017-851-200</b>	200 ml



<b>017-861-010</b>	10 ml
<b>017-861-020</b>	20 ml
<b>017-861-030</b>	30 ml
<b>017-861-050</b>	50 ml